

-2- Fin d'aspiration /début refoulement  
Fermeture clapet

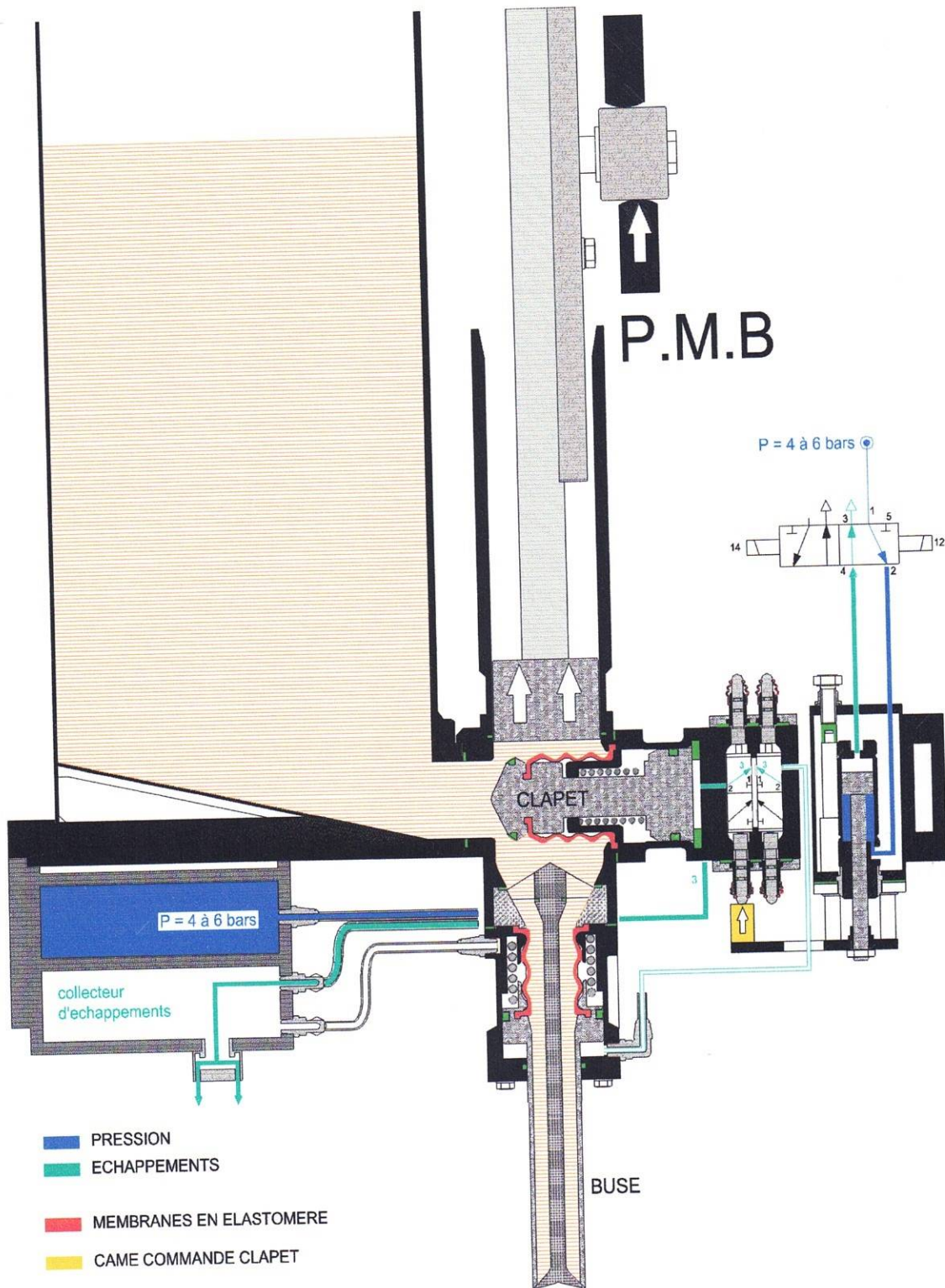

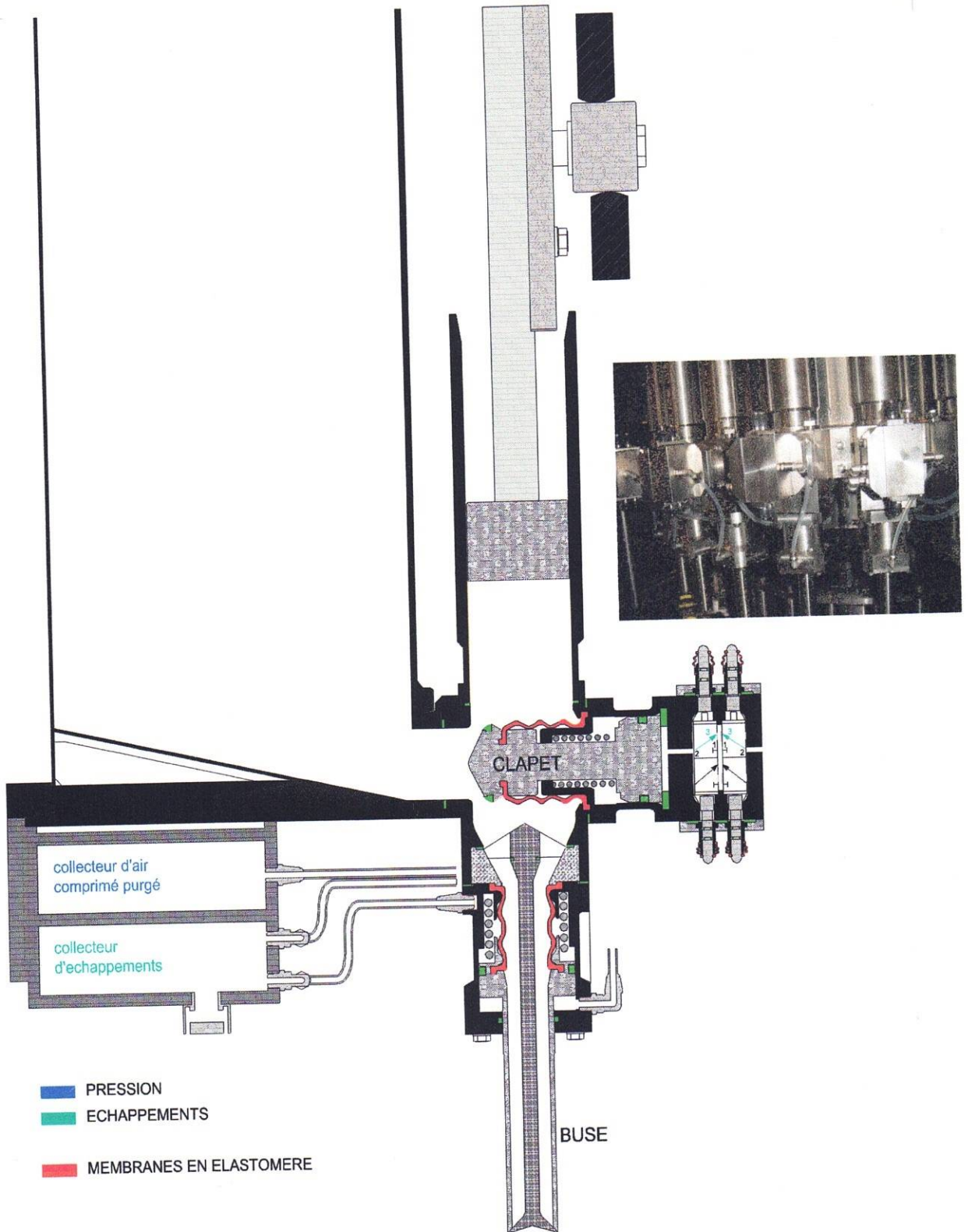

-1- Début aspiration  
Ouverture clapet



Doseur en position repos  
machine à l'arrêt



Wenn ein Gebinde vorhanden ist, wird von den Sensoren A und B zeitgleich ein Signal gegeben. A=1, B=1, dies Signal wird verzögert an die Steuerung weitergegeben.

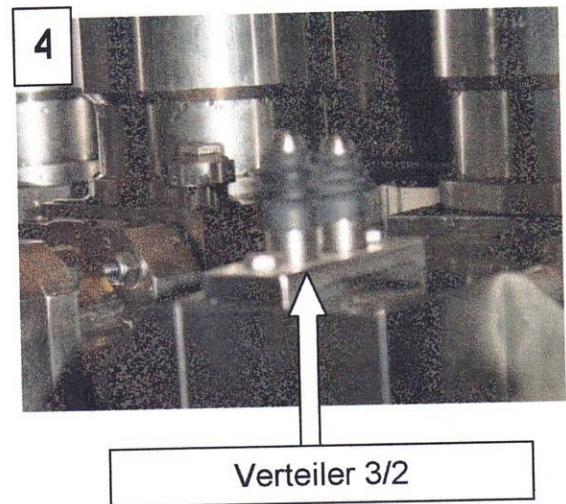
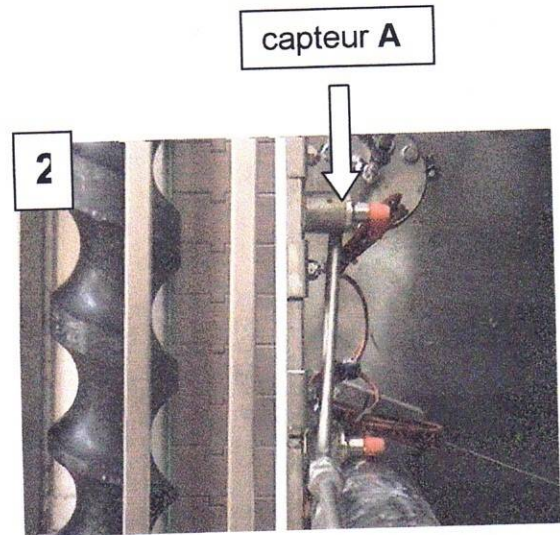
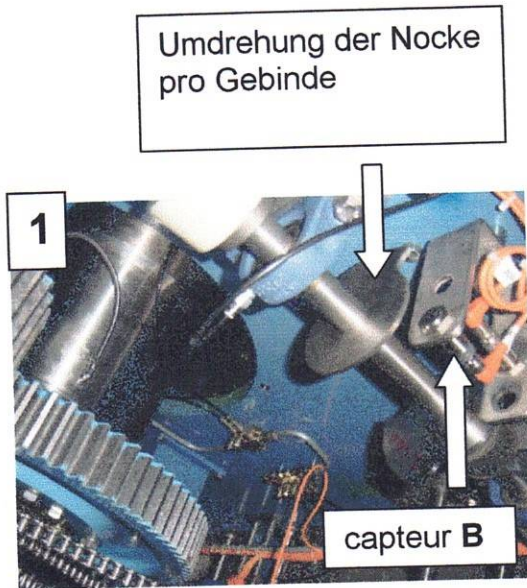

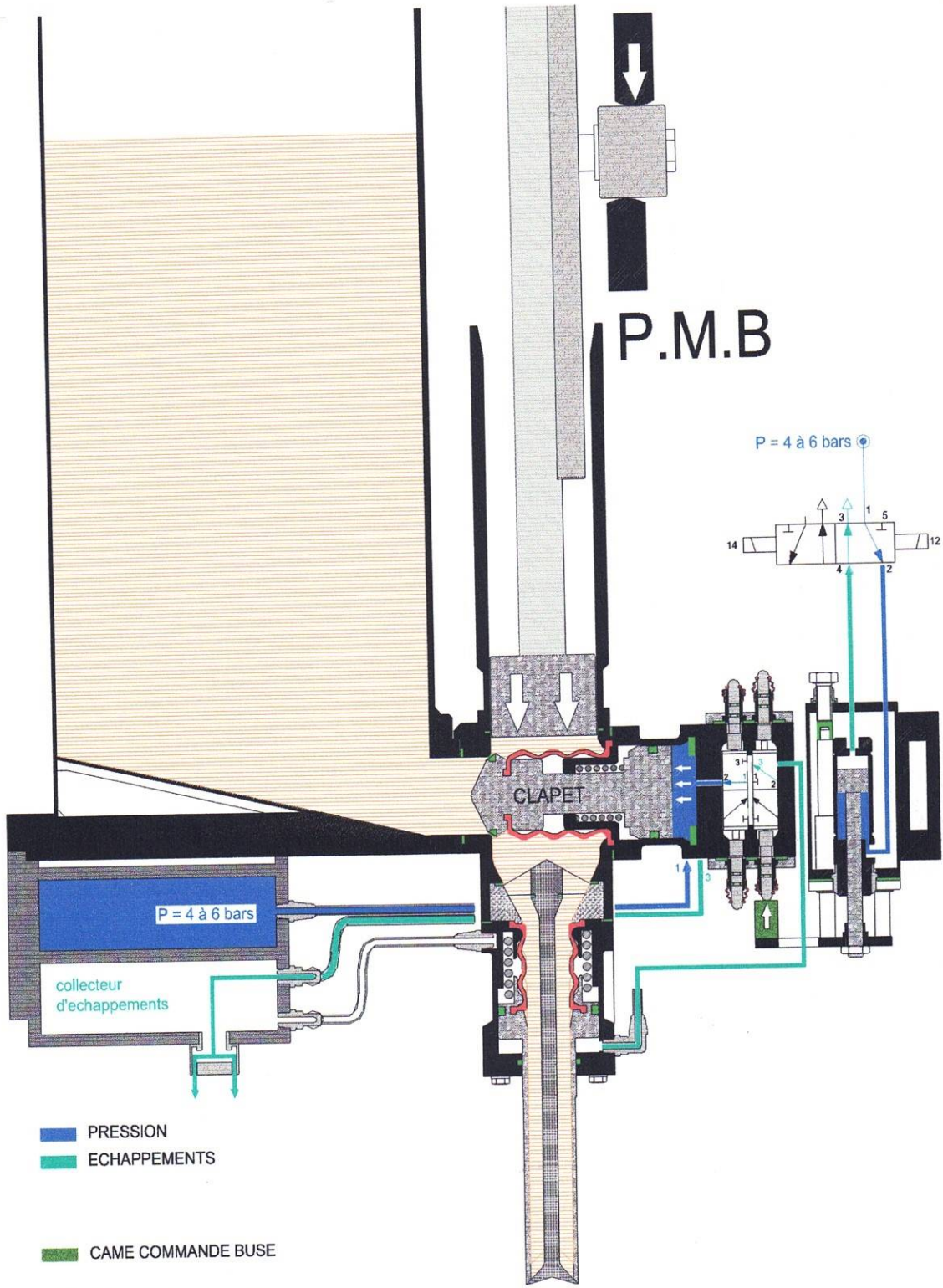

- █ PRESSION
- █ ECHAPPEMENTS
- █ CAME COMMANDE BUSE

-4- Fermeture buse  
Fin remplissage